

# ORWAK HORIZONTAL 15 AT

Our fully automated horizontal 15 ton baler provides effective compaction where space is limited. The baler can be delivered in three parts for easier internal transportation. We provide well-proven technology for special demands! The automatic tying and the continuous baling enable multi-shift operation.

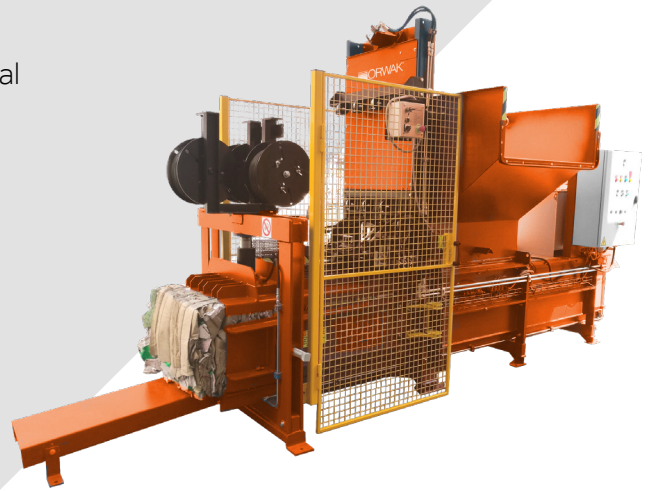

**AUTOMATIC  
SOLUTION**



**CAPACITY  
CARDBOARD**



**BALE WEIGHT  
CARDBOARD**

## ORWAK BENEFITS



### **MORE PRODUCTIVE USE OF TIME**

Less time spent on waste handling, more time for your core activities!

### **MORE SPACE & ORDER**

Our balers rapidly minimize the space the waste takes up, keeping aisles free and tidy.

### **LESS COSTS, MORE VALUE**

More compaction = less waste volume to transport. Fewer transports required results in lower transportation costs and reduced CO<sub>2</sub> emissions. Sorting at source yields a higher quality of waste material for recycling.

## WHY ORWAK HORIZONTAL?

- Effective large-scale waste handling
- Improved internal and external logistics
- Safe and comfortable working environment
- Excellent control over the throughput
- Increased income when delivering high-quality bales directly to the recycling industry.

**ORWAK**  
PART OF Sulo GROUP

# ORWAK HORIZONTAL 15 AT

Smart fully automated solution

## COMPACT AND CLEVER DESIGN

This compact baler fits where you need it to be! On demand, it can also be delivered in three parts for easier transportation to the installation site.

## CONTINUOUS FEEDING AND OUTPUT

A completely automated waste management solution designed for continuous infeed, automatic horizontal or vertical strapping system with adjustable wire links, which enables you to yield optimal output.



## OPTIMAL FEATURES

- Well proven technology
- Auto start (photocell) as standard
- High speed: fast throughput
- Adjustable bale length

## HORIZONTAL 15 AT IS OPTIMIZED FOR:

### PAPER

- Paper sacks
- Shredded paper
- Cardboard

### PLASTIC

- PET bottles

## A VARIETY OF INFEED OPTIONS

To fit the conditions in your environment, our horizontal balers offer a wide choice of infeed systems: manual, by bin, air-transport and conveyor belt.

Our balers can also easily be equipped with shredders, bottle presses, rufflers, strippers and different types of hoppers.

## OPTIONS

- Bin lifter
- Conveyor belt
- Cooling and heating systems

*More special options on demand*

## DIMENSIONS & SPECIFICATIONS

### TECHNICAL SPECIFICATIONS

MACHINE DIMENSIONS (LXWXH) EXCL BALE EXIT	FEED OPENING	INFEED CAPACITY	PRESS FORCE	MOTOR	SURFACE PRESSURE	CYCLES PER MINUTE	CHANNEL SECTION	OIL TANK CAPACITY
5172x1460x2495 mm	1030x650 mm	0.35 m <sup>3</sup>	15 ton	7,5 kW/10 Hp	4.28 kg/cm <sup>2</sup>	4	700x500 mm	200 L

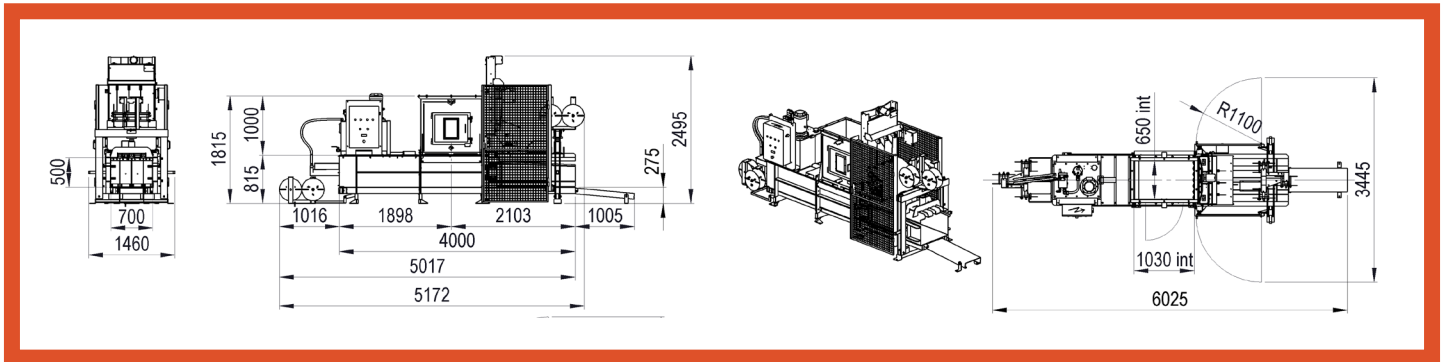

### TECHNICAL SPECIFICATIONS

TOTAL MACHINE WEIGHT	THEORETICAL OUTPUT	LOADING OUTPUT	AUTOMATIC BINDING	BALE SIZE (ADJUSTABLE LENGTH)	BALE WEIGHT CARDBOARD <small>DEPENDS ON BALE LENGTH</small>
2800 kg	84 m <sup>3</sup> /h	50 m <sup>3</sup> /h	3 wires Ø 2.7	700x500x600-1200 mm	80-150 kg

*We reserve the right to make changes to specifications without prior notice. Bale weights are dependent upon material type.*

## ORWAK AB

Svetsaregatan 4  
S-576 33 Sävsjö  
SWEDEN  
Tel: +46-(0)382-15700  
info@orwak.com

**ORWAK.COM**

