

ORWAK 3500

Our biggest vertical baler, a robust and strong heavy-duty machine perfect for any business with large amounts of packaging! ORWAK 3500 offers a safe, effective and profitable compaction solution. With 50 ton press force, it generates high-density bales of up to 500 kg.



**LARGE
VOLUME**



**BALE WEIGHT
CARDBOARD**



Complies to
EN 16500
Safety standard

ORWAK

ORWAK BENEFITS



MORE PRODUCTIVE USE OF TIME

Less time spent on waste handling, more time for your core activities!

MORE SPACE & ORDER

Our balers rapidly minimize the space the waste takes up, keeping aisles free and tidy.

LESS COSTS, MORE VALUE

More compaction = less waste volume to transport. Fewer transports required results in lower transportation costs and reduced CO₂ emissions. Sorting at source yields a higher quality of waste material for recycling.

WHY ORWAK 3500?

- Heavy-duty machine for strong and powerful compaction of large volumes of waste
- Produces high-density mill size bales
- Intelligent features, user-friendly panel and ready for the optional Connect communication service

ORWAK
PART OF **SULO** GROUP

ORWAK 3500

Our largest, most powerful baler generates big bales

HEAVY-DUTY APPLICATION

The ORWAK 3500 is a heavy-duty baler that effectively compacts really large amounts of packaging material.

SAFE DOOR-OPENING

"The latch and wheel" locking system on the lower door allows the operator to gradually open the door in a controlled way even when compacting expanding materials.



Dense mill size bale

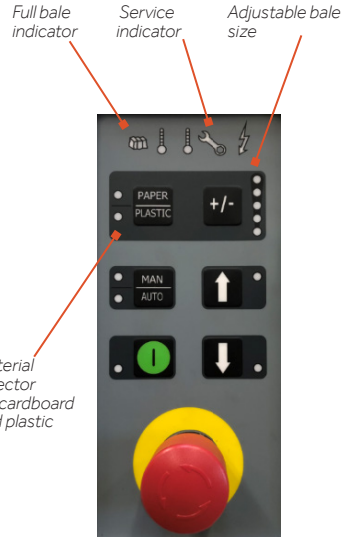

- User-friendly panel
- Bales can be secured by polyester straps or wire

ORWAK 3500 IS OPTIMIZED FOR:

PAPER

- Cardboard
- Shredded paper

PLASTIC FOIL

- Shrink film (LP)
- Plastic bags (LP)

READY TO COMMUNICATE

The PCB features data storage capacity, technical machine monitoring, communication opportunities and fulfills performance level D for personal safety.

The 3500 is ready to communicate when choosing the option Orwak Connect. It is a modem-based communication service enabling the baler to send updates and alerts to the caretaker as well as vital information and bale statistics to the web portal.

Complies with the EN 16500:2014 safety requirement standard for vertical balers

DIMENSIONS & SPECIFICATIONS

DIMENSIONS

A	B	C	D	E	F*
3225 mm	1765 mm	1140 mm	2410 mm	1068 mm	2340**

*Transport height

**Transport feet add 100 mm to the height

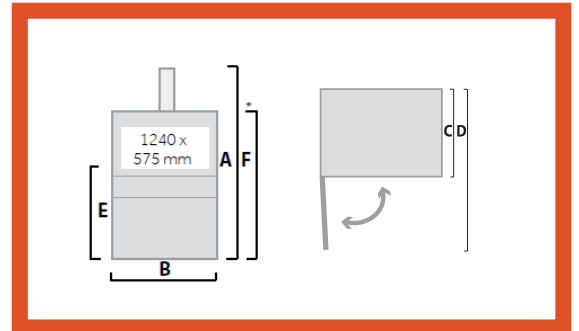

TECHNICAL SPECIFICATIONS

LOADING APERTURE	CYCLE TIME	PRESS FORCE	BALE SIZE	BALE WEIGHT	MACHINE WEIGHT	NOISE LEVEL	PROTECTION CLASS	OPERATING POWER
Width: 1240 mm Height: 575 mm	45 secs	50 ton, 500 kN	Width: 1100 mm Depth: 850 mm Height: 1240 mm	Cardboard: Up to 500 kg	2010 kg	74 db (A)	IP 55	3-phase 3x400 V, 50 Hz

We reserve the right to make changes to specifications without prior notice. Bale/bag/bin weights are dependent upon material type.

ORWAK AB

Svetsaregatan 4
S-576 33 Sävsjö
SWEDEN
Tel: +46-(0)382-15700
info@orwak.com

ORWAK.COM

ORWAK
PART OF SULO GROUP