

ORWAK

HORIZONTAL 15 AT

HORIZONTAL

CENTRALIZED WASTE HANDLING

Our fully automated horizontal 15 ton baler provides effective compaction where space is limited. The baler can be delivered in three parts for easier internal transportation. We provide well-proven technology for special demands! The automatic tying and continuous baling allows multi-shift operation.

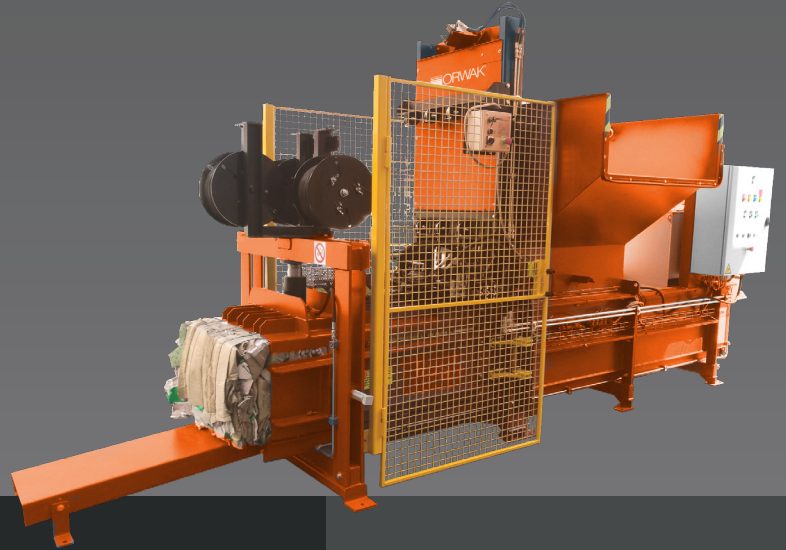

Automatic solution



0.5-2 T/H

CAPACITY
CARDBOARD

150 KG

BALE WEIGHT (UP TO)
CARDBOARD

Optimal features

WELL PROVEN TECHNOLOGY

based on more than 50 years of experience

AUTO START

equipped with photocell start as standard

HIGH SPEED

fast throughput of the material

ADJUSTABLE BALE LENGTH

individual settings to meet your needs

CHOICE BETWEEN VERTICAL & HORIZONTAL AUTOMATIC TYING

great versatility to bale different sorts of material



Why Orwak Horizontal?

- + Effective large-scale waste handling
- + Improved internal and external logistics
- + Safe and comfortable working environment
- + Excellent control over the throughput
- + Increased income when delivering high-quality bales directly to the recycling industry.

www.orwak.com

ORWAK[®]
PART OF **SULO** GROUP

Smart fully automated solution

OPTIMIZED FOR:

PAPER

- + Paper sacks
- + Shredded paper
- + Cardboard

PLASTIC

- + PET

COMPACT AND CLEVER DESIGN

This compact baler fits where you need it to be! On demand, it can also be delivered in three parts for easier transportation to the installation site.

CONTINUOUS FEEDING AND OUTPUT

A completely automated waste management solution designed for continuous infeed, automatic horizontal or vertical strapping system with adjustable wire links, which enables you to yield optimal output.

A VARIETY OF INFEED OPTIONS

To fit the conditions in your environment, our horizontal balers offer a wide choice of infeed systems: manual, by bin, air-transport and conveyor belt.

Our balers can also easily be equipped with shredders, bottle presses, rufflers, strippers and different types of hoppers.

HORIZONTAL 15 AT

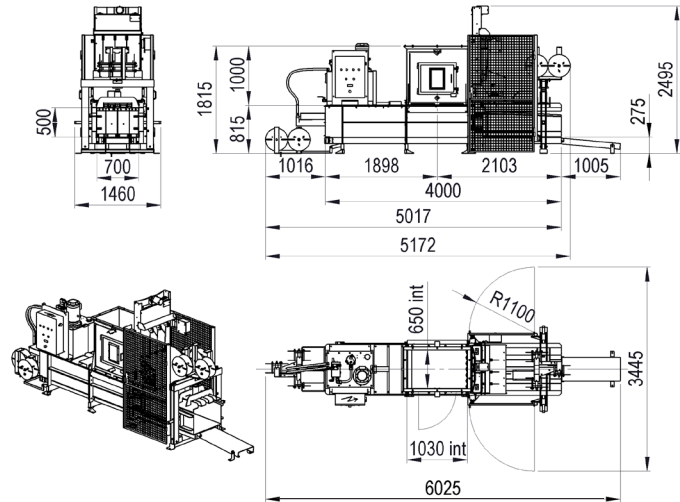

OPTIONS

- + HORIZONTAL TYING
- + BIN LIFTER
- + CONVEYOR BELT

+ COOLING & HEATING SYSTEMS

More special options on demand

DIMENSIONS & SPECIFICATIONS

TECHNICAL DATA

MODEL	15 AT
Machine dimensions (LxWxH mm without bale exit)	5172x1460x2495
Feed opening (mm)	1030x650
Infeed capacity (m ³)	0.35
Press force (t)	15
Motor (kW / Hp)	7.5/10
Surface pressure (kg/cm ²)	4.28
Cycles per minute	4
Channel section (mm)	700x500
Oil tank capacity (L)	200
Total machine weight (kg)	2800
Theoretical output (m ³ /h)	84
Loading output (m ³ /h)	50
Automatic binding	3 wires Ø 2.7
Bale size (mm)	700x500x
adjustable length (mm)	600-1200
Bale weight cardboard (kg)	80-150 kg
<i>depends on bale length</i>	



OPTION: CONVEYOR BELT

We reserve the right to make changes to specifications without prior notice. Bale weights are dependent upon material type.