

# ORWAK FLEX 5031

FLEX

**THE ORWAK FLEX 5031** offers simple and versatile compaction. Bag or bale the waste in the same unit! It is a classic concept now presented with a new fresh design!



## Versatile



**90** LBS  
BALE WEIGHT  
CARDBOARD

## Orwak benefits

### MORE PRODUCTIVE USE OF TIME

Less time spent on waste handling, more time for your core activities!

### MORE SPACE & ORDER

Our balers rapidly minimizes the space the waste takes up, keeping aisles free and tidy.

### LESS COSTS, MORE VALUE

More compaction = less waste volume to transport. Fewer transports required results in lower transportation costs and reduced CO<sub>2</sub> emissions. Sorting at source yields a higher quality of waste material for recycling.



## Why Orwak Flex?

- + Versatile compaction for many different application areas
- + Hygienic and safe compaction and disposal of mixed or hazardous waste
- + Special solutions for special needs

# ORWAK FLEX 5031

Versatile option

## ORWAK FLEX 5031 IS OPTIMIZED FOR:

### PAPER

- + Cardboard
- + Shredded
- + Paper sacks

### PLASTIC FOIL

- + Shrink film
- + Plastic bags

### SEMI-DRY WASTE

- + Bagged general waste

### VERSATILE - BAG OR BALE

The 5031 offers you full flexibility! Make a standard bale, compact waste in a bag and/or contain the bale in a plastic bag! The choice is yours! The same unit can do all those things for you!

ORWAK FLEX 5031 comes with a fresh design and a durable finish

Bales can also be contained in bags

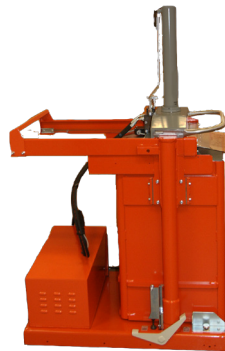

Mounted on wheels for easy manoeuvring when cleaning

### COMPACT DESIGN

Thanks to its compact design, the baler fits where you need it to be and is easy to install in any location.

### HIGH COMPACTION RATIO ON THE SPOT

The 5031 is a compact machine with a small footprint, but even though it requires little space, it still offers a high compaction ratio of up to 10:1!

### USER FRIENDLY

It is easy to fill in material in the open top-loading unit and it is safe and simple to manoeuvre. Removing the bag or bale is convenient thanks to a hoisting function.

### HYGIENIC WASTE COMPACTION

A compacted and well-sealed bag prevents leakage and odours. The unit is portable and designed for regular cleaning.

### OPTIONAL ACCESSORIES FOR FLEXIBILITY



Optional steel container for safe handling of, for example, tins and glass after compaction.



A simple-to-use option – the Orwak bale/bag lifter. Eliminates manual heavy lifting.

## DIMENSIONS & SPECIFICATIONS

### DIMENSIONS ORWAK FLEX 5031

A	B	C	D*	E
6'4"	31"	40"	8'9"	44"

### ENERGY CONSUMPTION

STANDBY MODE	MAXIMUM OPERATION ONE HOUR
---	660 W/H

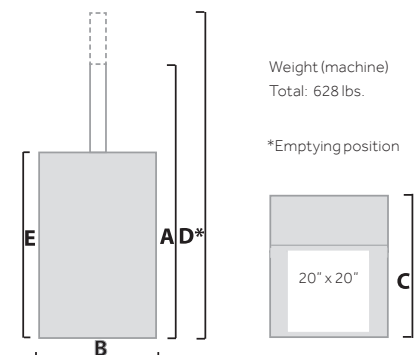

Weight (machine)  
Total: 628 lbs.

\*Emptying position

### TECHNICAL SPECIFICATIONS

LOADING APERTURE	CYCLE TIME	PRESS FORCE	BALE SIZE	BALE WEIGHT	NOISE LEVEL	PROTECTION CLASS	OPERATING POWER
Width: 20" Height: 20"	36 secs	6,600 lbs.	Width: 20" Depth: 28" Height: 20"	Cardboard: Up to 90 lbs Plastic: Up to 130 lbs	62 db (A)	IP 55	Single phase 115 V, 60 Hz, 10 A

We reserve the right to make changes to specifications without prior notice. Bale weights are dependent upon material type.

### Orwak North America, Inc.

9200 Globe Center Drive, Suite 130, Morrisville, NC 27560, USA  
Phone: +1-800-747-0449, Email: info@orwakbalers.com