

ORWAK MULTI 5070-COMBI

The ORWAK MULTI 5070-COMBI is a baler and an in-bin compactor in the same machine. It is a versatile all-round solution that takes care of both the bagged mixed waste and your recyclable packaging material.



VERSATILE



BALE WEIGHT
CARDBOARD



ORWAK BENEFITS



MORE PRODUCTIVE USE OF TIME

Less time spent on waste handling, more time for your core activities!

MORE SPACE & ORDER

Our balers rapidly minimize the space the waste takes up, keeping aisles free and tidy.

LESS COSTS, MORE VALUE

More compaction = less waste volume to transport. Fewer transports required results in lower transportation costs and reduced CO₂ emissions. Sorting at source yields a higher quality of waste material for recycling.

WHY ORWAK MULTI?

- Sorting and compaction of several waste types at source
- Top-loading of the material in open chambers
- Total freedom to increase capacity by adding additional chambers

**ORWAK**
PART OF Sulo GROUP

ORWAK MULTI 5070-COMBI

Allround solution

DUAL FUNCTION UNIT

When you opt for the 5070-COMBI, you get a baler for recyclables and an in-bin compactor in the same machine!

USER-FRIENDLY

The top-loading multi-chamber unit is simple to operate and convenient to feed with new material.

VERSATILE

It takes care of both dry and semi-wet waste as well as baling cardboard boxes, paper and plastics.

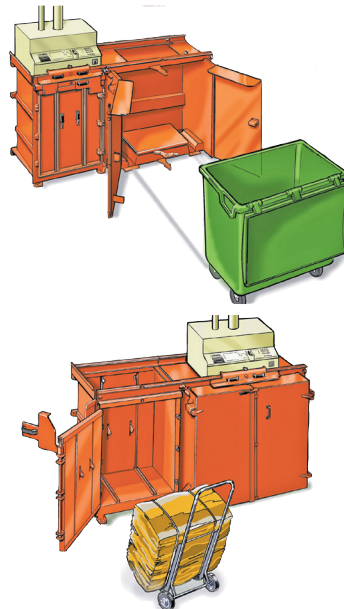

ORWAK MULTI 5070-COMBI IS OPTIMIZED FOR:

PAPER

- Paper sacks
- Cardboard
- Shredded paper

PLASTIC FOIL

- Shrink film
- Plastic bags

OTHER METALS

- Steel straps

OTHER PLASTICS

- Plastic straps

SEMI-DRY WASTE

- Bagged general waste

EXTENDABLE SYSTEM

Add an additional chamber to extend your sorting and compaction station!

DESIGNED FOR STANDARD BINS

It is suitable for most standard 660-liter wheeled bins.

BALE TROLLEY INCLUDED

The 5070-COMBI is always delivered with a trolley for easy baling and internal transportation of the bale.

DIMENSIONS & SPECIFICATIONS

DIMENSIONS				
A	B	C	D	E
660L/400L	660L/400L	660L/400L	660L/400L	660L/400L
7'5"/7'7"	100/77"	36/32" 40/36"*	66/68"	52/53"

*Including strap holders

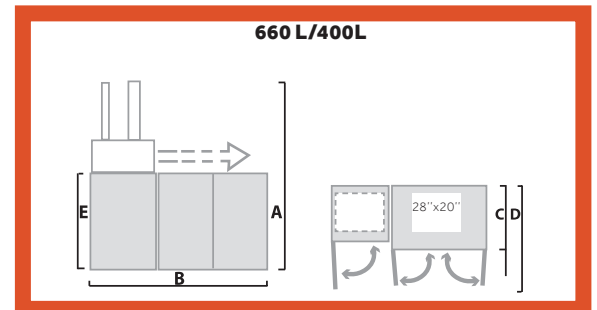

TECHNICAL SPECIFICATIONS								
LOADING APERTURE	CYCLE TIME	PRESS FORCE	BALE SIZE	BALE WEIGHT	MACHINE WEIGHT 660L/400L	NOISE LEVEL	PROTECTION CLASS	OPERATING POWER
Width: 28" Height: 20"	36 secs	6,600 lbs	Width: 28" Depth: 20" Height: 28"	Cardboard: Up to 110 lbs Plastic: Up to 180 lbs	Machine weight total: 1767/1360 lbs Bale chamber only: 431/431 lbs Bin chamber only: 990/583 lbs Press unit only: 345/345 lbs	< 70 db (A)	IP 55	Single phase 115 V, 60 Hz, 10 A

We reserve the right to make changes to specifications without prior notice. Bale/bag/bin weights are dependent upon material type.

ORWAK NORTH AMERICA, INC.

9200 Globe Center Drive, Suite 130
Morrisville
NC 27560, USA
Phone: +1-800-747-0449
Email: info@orwakbalers.com

ORWAKBALERS.COM

ORWAK
PART OF Julo GROUP